

LUCITE TOWEL RING

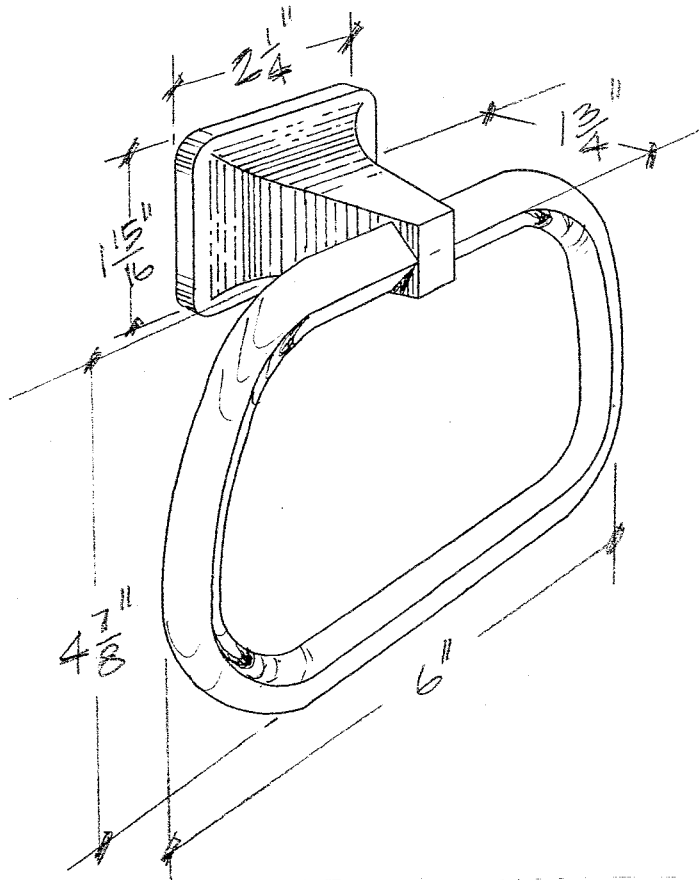

CONSTRUCTION:

Towel ring bracket is chrome plated zinc die-cast (zamak) designed for concealed screw mounting. Ring is clear lucite.

INSTALLATION:

Secure metal wall plate to stud or solid backing with mounting screws provided. Slip lucite towel ring over wall plate and tighten set screw until secure.

SPECIFICATION:

Lucite towel ring shall be model 714 by CWECO, Inc.