

Cweco

Commercial Washroom Equipment Company Incorporated

P.O. Box 2456, Gardena, CA 90247-0456 310-538-9440

1-800-292-9326 Outside CA FAX: 310-715-9188

FAX 1-800-232-9326

CWAT9

SURFACE MOUNTED ASH TRAY

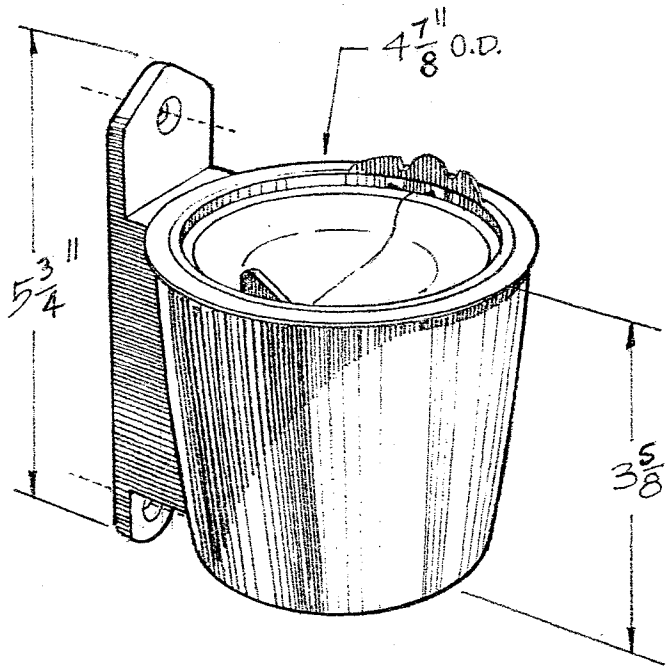

CONSTRUCTION:

Body is chrome plated steel.
Top and tip action blades are chrome plated steel.
Bracket is chrome plated zinc die-cast (zamak).
Removable liner is grey galvanized steel.

OPERATION:

Tight closing tip action blades prevent smouldering.
Removable liner allows easy servicing.

INSTALLATION:

Secure to stud or solid backing with mounting screws provided.

SPECIFICATION:

Surface mounted ash tray shall be model CWAT9 by CWECO, Inc.