



Commercial Washroom Equipment Company Incorporated

P.O. Box 2456, Gardena, CA 90247-0456 310-538-9440

1-800-292-9326 Outside CA FAX: 310-715-9188

FAX 1-800-232-9326

5159

B5159

SOAP DISH WITH DRAIN HOLES

Specify 5159 (satin SS) or B5159 (polished SS)

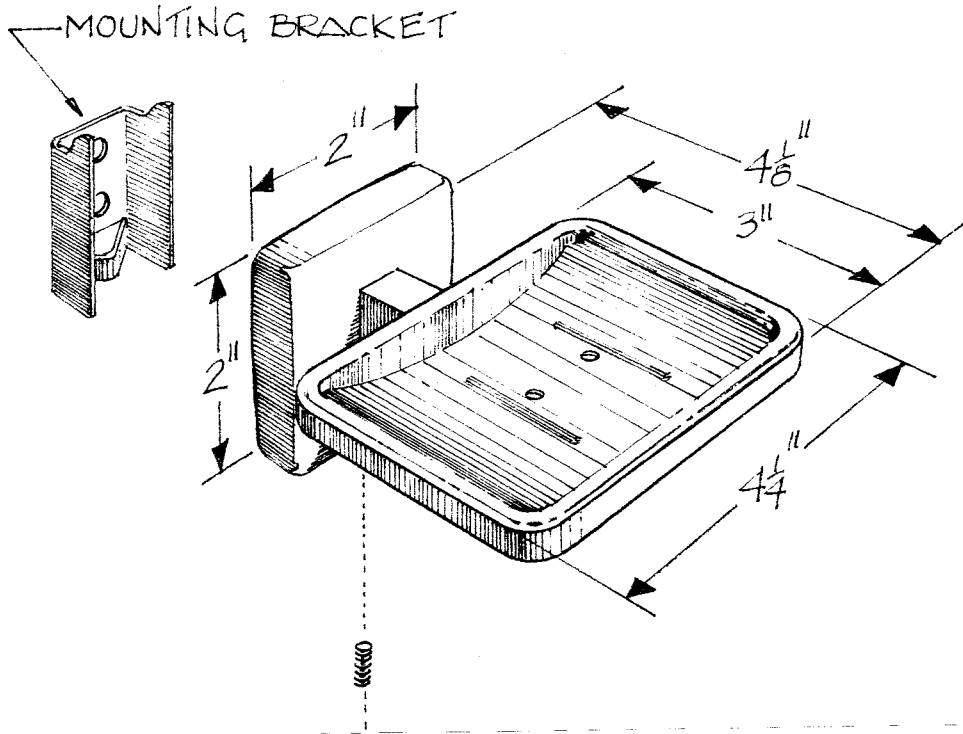

CONSTRUCTION:

Inner wall flange- 16 ga. type 304 stainless steel.
Cover wall flange- 22 ga. type 304 stainless steel.
Soap dish- 22 ga. type 304 stainless steel.
Wall plate- 16 ga. type 304 stainless steel.
All components welded construction designed for
concealed screw mounting.

INSTALLATION:

Secure stainless steel wall plate to stud or solid backing
with mounting screws provided. Slip soap dish over wall
plate and tighten set screw until secure.

SPECIFICATION:

Soap dish with drain holes shall be model 5159 (satin SS)
or B5159 (polished SS) by CWECO, Inc.