



Commercial Washroom Equipment Company Incorporated

P.O. Box 2456, Gardena, CA 90247-0456 310-538-9440
1-800-292-9326 Outside CA FAX: 310-715-9188

FAX 1-800-232-9326

CW-66

CW-2

CW-58A

CW-16A

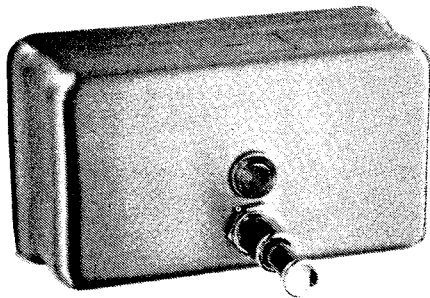

CW-66 — Lather
CW-58A — All Purpose

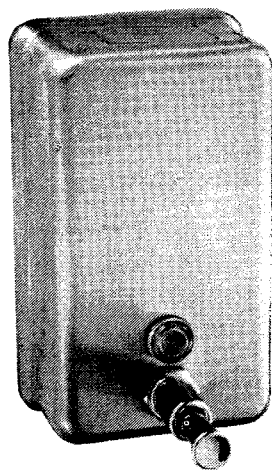
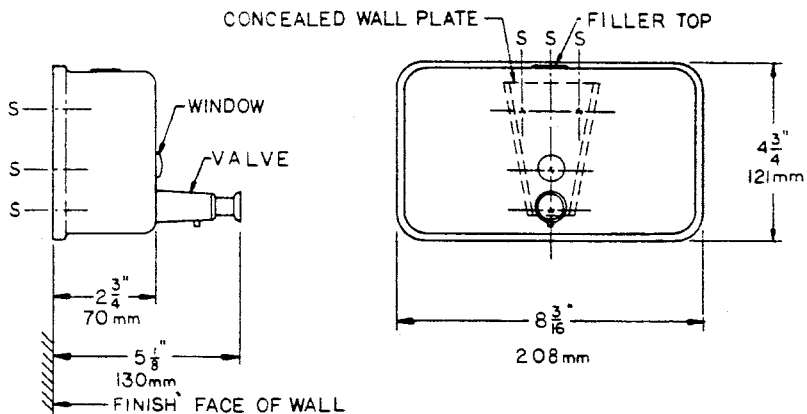

CW-2 — Lather
CW-16A — All Purpose

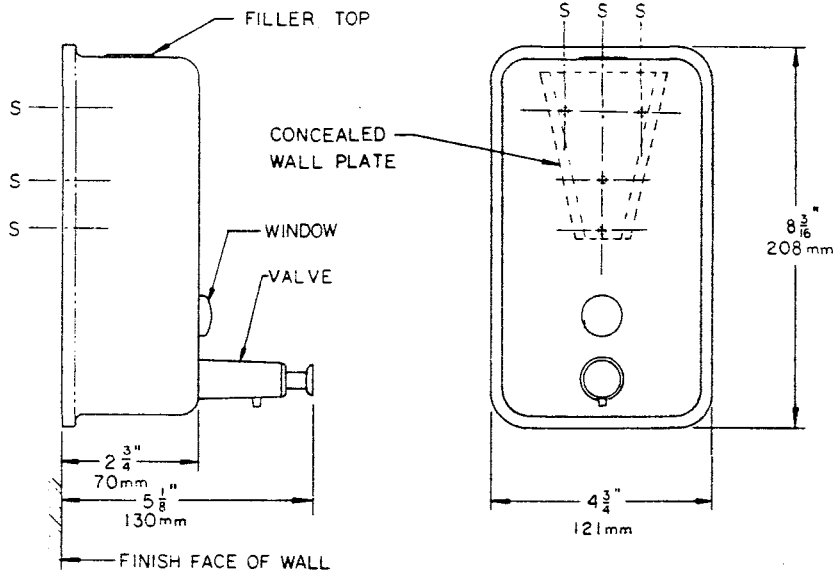

CONSTRUCTION: **BODY** fabricated of type 304 (18-8), 20 gauge stainless steel with exposed surfaces in architectural satin finish.
BACK fabricated of type 304 (18-8), 20 gauge stainless steel. Heliarc welded to body.
WALL PLATE of heavy gauge stainless steel.
SOAP VALVE has chrome plated brass housing with stainless steel mechanism. Internal checks prevent leakage.

CAPACITY: 40 oz. liquid soap.

OPERATION: Push-in valve dispenses measured amount of liquid soap with each stroke. Sight gauge indicates refill time. Filler hole cover requires special key to open.

NOTE: Liquid and lather valves operate best with any vegetable oil or coconut oil hand soap have a 10 to 15 percent concentration.

INSTALLATION: Secure separate mounting bracket to wall. Slide dispenser into place and secure locking screw through filler hole.